

DENVER®



USER MANUAL



MRD-51

WWW.DENVER-ELECTRONICS.COM

Please read this user manual carefully before start using the product.

CAUTION

TO PREVENT FIRE OR SHOCK HAZARD, DO NOT USE THIS PLUG WITH AN EXTENSION CORD, RECEPTACLE OR OTHER OUTLET UNLESS THE BLADES CAN BE FULLY INSERTED TO PREVENT BLADE EXPOSURE. TO PREVENT FIRE OR SHOCK HAZARD, DO NOT EXPOSE THIS APPLIANCE TO RAIN OR MOISTURE.

 <p>The LIGHTNING FLASH with arrowhead symbol, within an equilateral triangle is intended to alert the user to the presence of uninsulated 'dangerous voltage' within the product's enclosure that may be of sufficient magnitude to constitute a risk of electric shock to persons.</p>	<p>CAUTION RISK OF ELECTRIC SHOCK DO NOT OPEN</p> <p>WARNING : TO REDUCE THE RISK OF ELECTRIC SHOCK DO NOT REMOVE COVER (OR BACK), NO USER SERVICEABLE PARTS INSIDE REFER SERVICING TO QUALIFIED SERVICE PERSONNEL</p>	 <p>The exclamation point within an equilateral triangle is intended to alert the user to the presence of important operating and maintenance (servicing) instructions in the literature accompanying the appliance.</p>
---	--	---

IMPORTANT SAFETY INSTRUCTIONS

1. Read, keep and follow all these instructions in this manual.
2. Clean only with dry cloth.
3. Do not block any ventilation openings. Install in accordance with the manufacturer's instructions.
4. Do not install near any heat sources such as radiators, heat registers, stoves, or other apparatus (including amplifiers) that produce heat.
5. Protect the power cord from being walked on or pinched particularly at plugs, convenience receptacles, and point where they exit from the apparatus.
6. Unplug this apparatus during lightning storms or when unused for long periods of time.
7. Refer all servicing to qualified service personnel. Servicing is required when the apparatus has been damaged in any way, such as power-supply cord or plug is damaged, liquid has been spilled or objects have fallen into the apparatus, the apparatus has been exposed to rain or moisture, does not operate normally, or has been dropped.
8. This appliance shall not be exposed to dripping or splashing water and no object filled with liquids such as vases shall be placed on the apparatus.
9. Do not overload wall outlet.
10. Operate controls and buttons as described in the manual.
11. Store your CDs, cassettes in a cool area to avoid damage from heat.
12. When moving the set, be sure to first disconnect the power cord.

CLEANING THE CABINET

If the wooden cabinet becomes dusty please wipe it with a soft, non-abrasive dust cloth. Also don't use water or spray cleaners as this can damage the cabinet and the plastic/metal parts of the unit.

TECHNICAL SPECIFICATION

- Turntable speed: 33/45/78 RPM (Disc size 17.5/25/30cm)
- CD can play CD/CD-R/CD-RW/MP3
- USB can play MP3
- Cassette: C60 & C90 (C120 cassette is not recommended)
- Output power: 2x2.5W

PREPARATION FOR USE

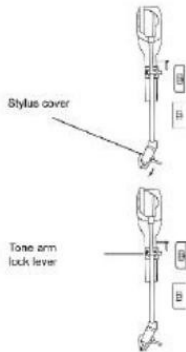
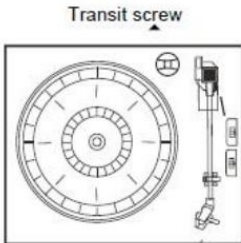

- Carefully remove the unit from the carton and remove all packing material from the unit.
- Unwind the AC power cord and extend it to its full length.
- Unwind the FM Antenna wire and extend it to its full length.
- Raise the lid to expose the turntable. The turntable has been secured for shipment with a transit screw. Use a coin or a screwdriver to turn the transit screw clockwise. This will allow the turntable to "float".

- Remove the opaque white plastic stylus cover from the phonograph stylus by sliding it in the direction of the arrow.
- Please pay attention to the stylus during operation because stylus damage is not covered by the warranty.
- Remove the the twist-tie that was used to secure the tone arm during shipment.

- Release the tone arm lock lever.

- Connect the power plug to your AC 220V, 50HZ outlet.

IMPORTANT: RAISING AN LOWERING THE TURNTABLE LID

To open the lid. Raise it as far as it can go until the lid support bracket locks in the position.

To close the lid. Pull forward the lid support bracket to release and then gently lower the lid.

TO AVOID DAMAGING THE CABINET OR THE LID, NEVER FORCE THE LID CLOSED. ALWAYS RAISE THE LID TO RELEASE THE LID SUPPORT BRACKET.

LOCATIIONS OF CONTROLS AND INDICATORS

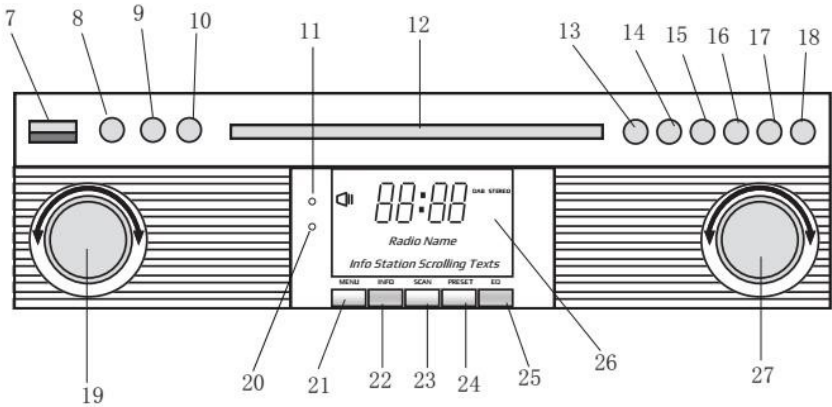

FRONT PANEL

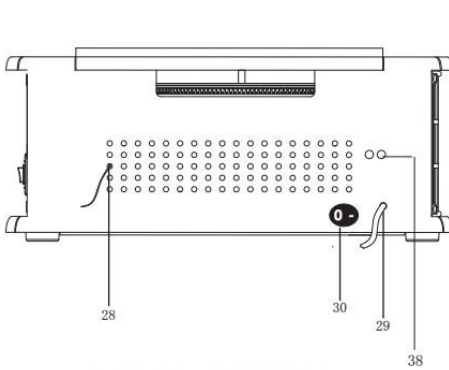

REAR VIEW

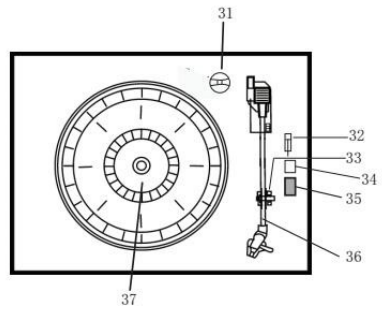

TURNTABLE

LOCATION OF CONTROLS

1. DUST COVER
2. COVER MECHANISM
3. TURNTABLE
4. SPEAKERS
5. TAPE STOP/EJECT BUTTON
6. CASSETTE MECHANISM
7. USB SOCKET

8. AUX-IN
9. 3.5mm HEADPHONE JACK
10. FUNCTION BUTTON (DAB/FM/CD/USB/PHONO/TAPE/AUX)
11. REMOTE SENSOR
12. CD DOOR
13. PLAR/PAUSE
14. STOP BUTTON
15. DN/F-R
16. UP/F-F
17. REC/DEL (RECORD BUTTON/DELETE BUTTON)
18. CD DOOR OPEN/CLOSE BUTTON
19. VOLUME KNOB/ POWER STANBY
20. POWER LED
21. DAB MENU BUTTON
22. DAB INFO BUTTON
23. DAB SCAN BUTTON
24. DAB PRESET BUTTON
25. DAB ENTER
26. LCM DISPLAY
27. TUNING BOTTON/PLAY.MODE
28. FM/DAB ANTENNA
29. AC CORD
30. ON/OFF SWITCH
31. ADAPTOR
32. TURNTABLE PAUSE SWITCH
33. PICK-UP HOLDER
34. Auto-stop ON/OFF
35. 33/45/78 RPM SPEED SELECTOR
36. TONE ARM
37. TURNTABLE
38. LINE OUT

REMOTE CONTROL

1. POWER ON/OFF
2. CD DOOR OPEN/CLOSE BUTTON
3. RECORD BUTTON
4. DELETE BUTTON5. MODE BUTTON
6. STOP BUTTON
7. REPEAT BUTTON/VOL+
8. PROGRAM BUTTON/VOL-
9. PLAY/PAUSE BUTTON
10. DAB SCAN BUTTON
11. INFO
12. SKIP-BUTTON/FAST FORWARD BUTTON
13. SKIP+ BUTTON/REWIND BUTTON
14. NUMERIC KEYBOARD
15. +10

16. ENTER
17. MENU
18. EQ
19. PRESET
20. TIMER

REMOTE BATTERY INSTALLATION

The infrared remote control requires 2 PCS UM-4 R03, AAA (3V) Battery

POWER ON/OFF

1. Press POWER to turn the system on. The power indicator lights up.
2. Press the function selector buttons (DAB/FM/CD/USB/TAPE/PHONO/AUX IN) to select the desired function.
3. Start to adjust the volume by using the volume control button.
4. When finished listening press POWER again to turn off the system. The power indicator goes off.

Remark: The unit is comply with ERP2, the unit will turn to Standby mode if there is no operation on the unit after 15 mins, please press POWER button 2 times if you want to re-start the unit.

DAB MODE

Press function button (10) (5 on remote) repeatedly to select DAB mode. Press SKIP+/- (16/15) (12/13 on remote) to search the program

DAB MENU

Press MENU (21) (17 on remote) to access to the options.

1. Full Scan: select this option to perform a full scan of the available DAB programs. You can press SCAN (23) to perform the same action.
2. Manual Tune: select this option to select manually the DAB frequency
3. DRC: select this option to choose between DRC low, DRC high and DRC off.
4. Prune: select this option to choose between PRUNE stations on or off.

DAB PRESET

You can program a maximum of 20 preset radio stations.

1. Press and hold PRESET (24) (19 on remote). PRESET STORE will appear on display. Press SKIP+/- (16/15) (12/13 on remote) to select the preset number. Press ENTER (9) (16 on remote) to confirm.
2. Press PRESET (24) (19 on remote) to navigate through the presets.

DAB INFO

Repeatedly press INFO (22) (18 on remote) to see the following information: NAME/KBPS/DATE /TIME.

FM MODE

Press function button (10) (5 on remote) repeatedly to select FM mode. Turn the TUNING KNOB (27) to manually select the frequency

FM MENU

Press MENU (21) (17 on remote) to access to the options.

1. Scan Setting: select this option to choose between scanning all stations or only the strong stations.
2. Audio Setting: select this option to choose between forcing mono audio or allowing stereo Sound.

FM PRESET

See DAB PRESET instructions.

FM INFO

Repeatedly press INFO (22) (18 on remote) to see the following informations: KIND OF PROGRAM/FREQUENCY/AUDIO/DATE/TIME.

CD OPERATION

- 1.— Press the CD/USB button to enter CD mode, the “---” and ‘DISC’ icon will be shown on the screen. The unit can play CD, CD-R and CD-RW.
- 2.— Press the OP/CL button top open the CD drawer.
- 3.— Place your disc in the CD drawer with the label side facing up.
- 4.— Press the OP/CL button again to close the CD drawer. Playback will automatically start from the first track.
- 5.— MP3 icon will be shown if MP3 file is detected in the disc.



PLAYING CASSETTE

Note: Before inserting the tape in the player be sure that there is no excess slack in the cassette that could jam the mechanism.

- 1.— Press POWER to turn the system on.
- 2.— Press TAPE button to enter TAPE mode.

- 3.—Insert your cassette into the slot located on the right side of the cabinet, as shown in the illustration, with the side you wish to play facing up and the open end on the right side.

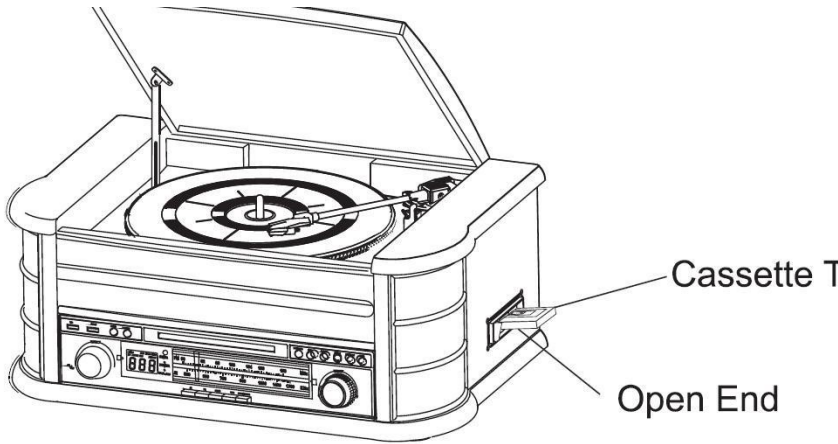

- 4.—Cassette playback begins as soon as the tape is inserted. Adjust the VOLUME control to the desired level.



- 5.—To advance the tape rapidly, depress the button approximately half way. The tape will move forward rapidly as long as the button is depressed. Normal playback will resume when the button is released



- 6.—When the tape ends, the player stops automatically. Depress the button completely to remove the tape from the player. You may depress button to stop playing the tape at any time.

- 7.—Press POWER again to turn the system off.

PLAYING VINYL RECORDS

The system includes a full-size, 3 speed, belt-drive turntable. You can play 33, 45 and 78rpm records.

- 1.—Press **POWER** to turn the system on.
- 2.—Press the PHONO button to enter the PHONO mode.
- 3.—Make sure you have removed the stylus cover from the stylus and have released the tone arm lock

that

- 4.—secured the tone arm to the tone arm rest.
- 5.—Set the turntable speed selector to appropriate speed 33, 45 or 78rpm. If you are playing 45 rpm singles, place the 45rpm adapter on the centre spindle.
- 6.—Place your record on the the centre spindle.

- 7.**—Raise the cue lever to lift the tone arm of its rest. Move the tone arm to the edge of the record. The turntable starts automatically. Use the cue lever to gently lower the tone arm onto the record.
- 8.**—Adjust the volume control to the desired level.
- 9.**—When the tone arm reaches the end of the record it automatically returns to the tone arm rest and the record player stops.
- 10.**—Press POWER again to turn the system off. The POWER indicator goes OFF.

Note: Do not turn or stop the turntable manually. Moving or jarring the turntable without securing the tone arm clamp could result in damage to the tone arm.

AUX IN OPERATION

Connect the audio system into the AUX IN jack on the rear panel, Press the PHONO/AUX IN button. Start playing from the connected device.

USB OPERATION

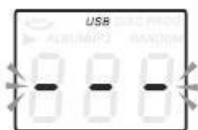

- 1.**—Press the CD/USB button first and the FUNCTION button to enter USB mode. The '---' and USB icon will be shown.
- 2.**—Insert a USB flash device into the USB socket.
- 3.**—PLAY/PAUSE, DN/UP and stop functions are the same as CD functions.

Note: You may press the FUNCTION on the panel or long press PLAY/PAUSE button on the remote control for 2 seconds to change the playing mode between CD and USB.

PLAYING IN MP3 MODE (CD/USB)

- 1.**—Press PLAY/PAUSE button to start or pause playback selected track.
- 2.**—While playing the song, the song number and folder number of the selected track will be shown in the display.
- 3.**—You can stop the playback at any time by pressing the STOP button.

TRACK SKIP AND HIGH SPEED TRACK SEARCH IN CD/USB MODE

During CD/USB playback press UP/F.F () or DN/F.R () button on the unit front panel or on the remote control repeatedly to change track. To rapidly search forward or backwards within a track press and hold UP/F.F (press UP/F.F () or DN/F.R () button. To skip 10 tracks back or forth then press TRACK-10 or TRACK+10 on the remote control.

USB RECORDING

1.—CD recording

Insert USB flash drive into the USB socket. Then press CD/USB button. Place CD into the CD drawer and play the track which will be recorded. Press RECORD button twice to start recording. If all CD is played, Then all tracks will be recorded. NOTE: Recording will fail if pressing STOP button during recording

2.—MP3 DISC recording

Insert USB flash drive into the USB socket. Then press CD/USB button. Place CD with MP3 files into the CD drawer and play the MP3 track which will be recorded. Press RECORD button twice to start recording. If all MP3 files is played, Then all tracks will be recorded. NOTE: Recording will fail if pressing STOP button during recording

3.—Cassette recording

Insert USB flash drive into the USB socket. Then press TAPE button. Place the cassette into the socket. Play cassette. Press RECORD button twice to start recording. Press STOP button to stop recording.

4.—Vinyl recording

Insert USB flash drive into the USB socket. Then press PHONO/AUX IN button. Play the vinyl and press RECORD button twice to start recording. Press STOP button to stop recording.

5.—AUX IN recording

Insert USB flash drive into the USB socket. Connect the external audio device into the AUX jack on the rear panel. Then press PHONO/AUX IN button and play audio and press RECORD button twice to start recording.

DELETE TRACKS FROM USB DISC

Press CD/USB button on the front panel or long press PLAY/PAUSE on remote control to select USB mode. Select the track and press delete for 2 seconds and the track is deleted.

ALLE RECHTE VORBEHALTEN, URHEBERRECHTE DENVER ELECTRONICS A/S

DENVER®

www.denver-electronics.com



Electric and electronic equipment contains materials, components and substances that can be hazardous to your health and the environment, if the waste material (discarded electric and electronic equipment) is not handled correctly.

Electric and electronic equipment is marked with the crossed out trash can symbol, seen below. This symbol signifies that electric and electronic equipment should not be disposed of with other household waste, but should be disposed of separately.

All cities have established collection points, where electric and electronic equipment can either be submitted free of charge at recycling stations and other collection sites, or be collected from the households. Additional information is available at the technical department of your city. Hereby, Inter Sales A/S declares that the radio equipment type MRD-51 is in compliance with Directive 2014/53/EU. The full text of the EU declaration of conformity is available at the following internet address:

Please enter: www.denver-electronics.com and then click the search ICON on top line of website.

Write model number: MRD-51

Now enter product page, and red directive is found under downloads/other downloads

Operating Frequency Range: FM:87.5-108MHz DAB:168-240MHz

Max Output Power: 2*2,5W

DENVER ELECTRONICS A/S

Omega 5A, Soefte
DK-8382 Hinnerup
Denmark
[Facebook.com/denverelectronics](https://www.facebook.com/denverelectronics)

