

## BLUETOOTH SPEAKER WITH LED LIGHTS

Model No.: BTB-410



Read this booklet thoroughly before using and save it for future reference

⚠ Unit must be fully charged before use

### Guide to the Appliance

1. TWEETER X 2
2. FUNCTION/STANDBY BUTTON
3. P-MODE/M./ECHO BUTTON
4. 10/M./FOLD.- BUTTON
5. ◀/TUN.- BUTTON
6. VOL.- BUTTON
7. ▶/TUN.+ BUTTON
8. VOL.+ BUTTON
9. ▶/PAIR/SCAN BUTTON
10. 10/M./FOLD.+ BUTTON
11. EQ/LIGHT BUTTON
12. PARI INDICATOR
13. CHARGE INDICATOR
14. LCD DISPLAY
15. SPEAKER X 2
16. HANDLE
17. MIC VOL. KNOB
18. 6.3mm MIC JACK 1
19. 6.3mm MIC JACK 2
20. LIGHT BAR
21. 3.5mm AUX IN JACK
22. USB PORT
23. POWER ON/OFF BUTTON
24. VENTILATION HOLES
25. AC SOCKET
26. Antenna

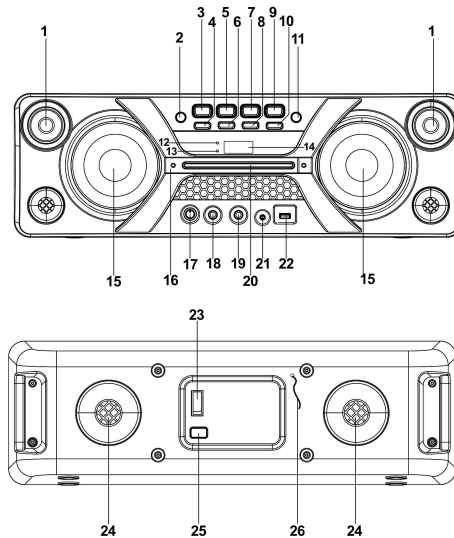

## Getting Started

### POWER SOURCE

This unit works with rechargeable lead-acid battery (the battery capacity 4000mAh). Fully charge the unit (around 7 hours) before using the product for the first time. The playback time has about 2 hours after full charging. Unplug the AC Power cord from the AC socket to work on the battery pack after fully charged. Plugging the AC Power cord while the battery pack is attached initiates the charging of this battery, the charge LED indicator lights red during charging, when the battery is fully charged the indicator will turn to green. When the unit is with low battery, the LED indicator will flash in red. Warning: Do not change the battery, only high-qualified personnel can perform this operation.

## OPERATION INSTRUCTION

### BASIC FUNCTION

Eng-1

#### TURNING THE UNIT ON/OFF

Press the power **ON/OFF** button on the rear cabinet to switch the unit on or off.

**NOTE:** In USB/Bluetooth/AUX mode, when the unit is not providing the main function for around 15 minutes, the unit will automatically switch into standby mode. Press the **FUNCTION/⏻** button to turn on the unit again.

Please note that low volume setting in the audio source may be recognized as “no audio signal”, this will affect the capability of signal detection from the device and can also originate an automatic switch into standby mode. If this happens please reactivate the audio signal transmission or increase the volume setting on the audio source player in order to resume playback.

**Electrostatic Discharge hints** – The unit may reset or may not reset to normal operation mode due to electrostatic discharge, just switch it off and reconnect again.

#### SETTING THE FUNCTION MODE

To change the function modes, press the **FUNCTION/⏻** button repeatedly to choose USB/AUX/BLUETOOTH/RADIO function.

#### ADJUSTING THE VOLUME

1. Press the **VOL.+** or **VOL.-** button to increase or decrease the music volume.
2. Rotate the **MIC VOL.** knob on the unit to increase or decrease the microphone volume.

#### EQUALIZER (EQ) FUNCTION

This unit has a built-in equalizer system, press the **EQ/LIGHT** button on unit to select a setting that best matches the music style: FLAT, POP, CLASSIC, JAZZ, and ROCK.

#### MICROPHONE ECHO ADJUSTMENT

Press and hold the **P-MODE/M./ECHO** button on unit to turn on or turn off the microphone echo effect. When the echo effect is on, the display will show “ECHO”.

#### FLASHING LIGHT

There are 5 modes for the DISCO LED lighting above the speakers. Press and hold the **EQ/LIGHT** button to choose the desired light mode. To turn off the light effect, press and hold the **EQ/LIGHT** button until **OFF** shows on the display.

- L-1: Blue LED will be on constantly when it is selected.
- L-2: Blue LED will be on flashing mode.
- L-3: Red LED will be on constantly.
- L-4: Red LED will be on flashing mode.
- L-5: 7 colors LED will be on flashing mode.

There's a light bar above the handle, the white light on when the Blue/Red LED on constantly, the bar will keep flashing when LED in flashing mode. Press and hold the **EQ/LIGHT** button until **OFF** shows on the display to turn it off together with the disco light.

## RADIO OPERATION

Listen to FM radio broadcasts. Press the **FUNCTION/↵** button on the unit to choose FM mode, the display will read the radio frequency.

Eng-2

Note: In order to get the best reception, extend the FM wired ANT. on the rear cabinet to its full length before use. If stereo signal is received, the display will show the "ST" indicator.

### TUNING TO A RADIO STATION

If you know the station frequency that you want to tune to directly:

- Tune to a station by pressing the **▶▶/TUN.+** or **◀◀/TUN.-** button repeatedly. The station frequency will show on the display.
- Press and hold the **▶▶/TUN.+** or **◀◀/TUN.-** button to quick scan the stations that with strong signal.

### AUTO PRESET MEMORY/SCAN

To scan for stations within reception range and save them to preset memory automatically, press and hold the **PLAY/PAUSE/PAIR/SCAN** button. After the unit is finished scanning, the unit will automatically tune to preset number 1 (P01).

### MANUAL PRESET MEMORY OPERATION

Choose which stations to save in preset memory instead of scanning automatically.

1. Use the **▶▶/TUN.+** or **◀◀/TUN.-** button to tune to the station that you want to save as a preset (e.g., 93.1).
2. Press the **P-MODE/M./ECHO** button. "**P01**" will flash on the display to indicate that you are saving the station as Preset Memory 01. (To change the preset memory number, press the **10/M./FOLD.+** or **10/M./FOLD.-** buttons.)
3. Press the **P-MODE/M./ECHO** button to finish saving the station (e.g., P01 is now set to 93.1).
4. To save another station, repeat steps 1 to 3. You may save up to 30 FM stations.

#### To tune to a preset station:

- To tune to the next preset station, press the **10/M./FOLD.+** button.
- To tune to the previous preset, press the **10/M./FOLD.-** button.

## USB OPERATION

1. Press the **FUNCTION/↵** button on unit to select USB mode.
2. Plug the USB memory stick to the USB port on top of the unit. Playback will start automatically.
3. To pause playback, press the **PLAY/PAUSE/PAIR/SCAN** button on unit. The playing time will flash on the display.
4. To resume playback, press the **PLAY/PAUSE/PAIR/SCAN** button again.
5. To select a desired track, press the **▶▶/TUN.+** or **◀◀/TUN.-** button respectively during playing until the desired track appears on the display. The unit will start play automatically.
6. To search for a particular passage during playback, press and hold the **▶▶/TUN.+** or **◀◀/TUN.-** button to scan the current playing track at high speed until desired point (passage) appears, then release the button for normal playback mode.

Eng-3

To select a song which track number exceeds 10, press the **10/M./FOLD.+** or **10/M./FOLD.-** button each time to skip forward/backward 10 tracks, then press the **▶▶/TUN.+** or **◀◀/TUN.-** button to select desired track.

7. To select a desired folder (if the USB contains more than one folder), press and hold the **10/M./FOLD.+** or **10/M./FOLD.-** button each time to skip forward/backward a folder, then press the **▶▶/TUN.+** or **◀◀/TUN.-** button to select desired track.

**Important: The USB port is intended for data transfer only, other devices cannot be used with this USB connection. The use of USB extension cords is not recommended. Don't plug the USB from the unit when playing or reading the USB device.**

### REPEAT PLAY

You can play one track or all tracks on the USB repeatedly.

#### To repeat a single track

1. Press **P-MODE/M./ECHO** button on unit during play, the display will show "↻" and the current track will be played over and over again.
2. To cancel repeat play, press **P-MODE/M./ECHO** button on unit until "↻" disappears from the display.

#### To repeat all the tracks

1. Press **P-MODE/M./ECHO** button on unit until the "C. C." shows steadily on the display, all tracks on the USB will be played over and over again.
2. To cancel repeat play, press the **P-MODE/M./ECHO** button on unit until "C. C." disappears from the display.

#### To repeat the folder (only for USB which contains more than one folder)

1. Press the **P-MODE/M./ECHO** button on unit until "C. C. FOLDER" shows steadily on the display, the current folder will be repeated over and over again.
2. To cancel repeat play, press the **P-MODE/M./ECHO** button on unit until "C. C. FOLDER" disappears from the display.

### RANDOM PLAY

Press the **P-MODE/M./ECHO** button on unit in play mode till the "RAND" shows steadily on the display, the random play will start from next track automatically. Press the **P-MODE/M./ECHO** button on unit again until the "RAND" disappears from the display to cancel.

## BLUETOOTH OPERATION

1. Press the **FUNCTION/↵** button on unit to switch to BLUETOOTH function, the LCD will display "bt" and the pair indicator will flash at high speed.
2. Turn on the Bluetooth function on the device, scan the unit "BTB-410" and connect, then input the password 0000 if required, the pair indicator keep light up to indicate connection done, and the display will show "bt". Press Play to start playback.

3. Adjust the **VOLUME** on the unit or on the external device to increase or decrease the music volume to your desired level.
4. Press and hold the **PLAY/PAUSE/PAIR/SCAN** button to disconnect Bluetooth.

Note: The Bluetooth works best within 10 meters in open air.

## AUX-IN OPERATION

1. Press the **FUNCTION/↵** button on unit to select the "AUX" mode.
2. Connect your audio device to the AUX IN jack on the top panel of the unit with an AUX IN cable.(audio cable is not included)

Eng-4

Adjust the **VOLUME** on the unit or on the external device to increase or decrease the music volume to your desired level.

3. Control the playback with your audio device.

## MIC JACK OPERATION

Microphone input is available in all modes.

1. Connect your microphone to the two 6.3mm **MIC JACK** on the unit.
2. Rotate the **MIC VOL.** knob on the unit to increase or decrease the microphone volume.
3. Press and hold the **P-MODE/M./ECHO** button to turn on or turn off the microphone echo effect.

## Technical Specifications

### GENERAL

Power Requirements	AC100-240V~60/50Hz
Power consumption	33W
Power output	MAX 20W X 2
FM frequency	FM 87.5-108MHz
AUX in jack	3.5mm
Microphone jack	6.3mm
Work temperature	5°C - + 40°C

### Bluetooth

Communication system	Bluetooth Standard version 2.1+EDR
Reception Range	10 meter (line-of-sight distance)
Compatible Bluetooth profiles	Advanced Audio Distribution Profile (A2DP)

### ACCESSORIES

Instruction Manual x 1pc  
AC Cord x 1pc

**Note:** Specifications are subject to change for continuous improvement without prior notice.

Eng-5

DENVER®

www.denver-electronics.com



Electric and electronic equipment and included batteries contains materials, components and substances that can be hazardous to your health and the environment, if the waste material (discarded electric and electronic equipment and batteries) is not handled correctly.

Electric and electronic equipment and batteries is marked with the crossed out trash can symbol, seen below. This symbol signifies that electric and electronic equipment and batteries should not be disposed of with other household waste, but should be disposed of separately.

As the end user it is important that you submit your used batteries to the appropriate and designated facility. In this manner you make sure that the batteries are recycled in accordance with legislature and will not harm the environment.

All cities have established collection points, where electric and electronic equipment and batteries can either be submitted free of charge at recycling stations and other collection sites, or be collected from the households. Additional information is available at the technical department of your city.

Hereby, Inter Sales A/S declares that the radio equipment type BTB-410 is in compliance with Directive 2014/53/EU. The full text of the EU declaration of conformity is available at the following internet address: <http://www.denver-electronics.com/denver-btb-410/>

Operating Frequency Range:2402-2480MHz

Max Output Power:20W×2

Imported by:

DENVER ELECTRONICS A/S

Omega 5A, Soeften

DK-8382 Hinnerup

Denmark

[www.facebook.com/denverelectronics](http://www.facebook.com/denverelectronics)