

DENVER[®]

SW-450 SMARTWATCH User's Guide



www.denver-electronics.com



www.facebook.com/denverelectronics

ENGLISH

Caution – please read carefully!

- Do not try to open your smartwatch.
- Do not expose to water or high moisture. The smartwatch is not waterproof.
- Only charge with the original charging cable included in this package.
- Do not attempt to replace the smartwatch battery yourself. You may damage the battery which can cause overheating and injury. The lithium battery should be replaced only by a skilled engineer and must be recycled or disposed in a proper way.
- To avoid damaging the smartwatch, do not place it near water like vases, filled sinks, bathtubs etc.
- If using a PC in order to charge the smartwatch (via the USB port), please make sure the PC is turned on. If it goes into hibernate mode, it will stop charging.
- It is also possible to use USB charger for e.g. smartphone or tablet. If you use that, make sure to read the safety instructions for the particular adaptor.
- Correct disposal of this product. This marking indicates that this product should not be disposed with other household wastes throughout the EU. To prevent possible harm to the environment or human health from uncontrolled waste disposal, recycle it responsibly to promote the sustainable reuse of material resources. To return your used device, please use the return and connect systems or contact the retailer where the product was purchased.
- Please notice, the heartrate sensor in this smartwatch is not a medical device and cannot be used for that purpose. If you have a condition where you or your doctor want to monitor your heartrate, you

should use a professional medical device instead. This smartwatch heartrate sensor is meant for use when doing sports and being active.

Please consult with your doctor before use, if you have pacemaker or other things that might be affected by using optical heartrate sensor.

- Congratulations with your new DENVER SW-450 Smartwatch. This watch has a lot of smart functions, so we suggest that you take a few minutes and read this short manual.

Main features:

- Bluetooth smartwatch with heartrate sensor
- Multi-Sport mode (running, walking, indoor run & trail run)
- Track your sport performance, get heartrate shown
- Use it as pedometer to track your daily steps and quality of sleep
- Synchronize phonebook and answer or reject calls directly on the watch
- Display SMS, emails, calendar events and social media activity
- Remote control music playback, remote capture photo on smartphone
- 200mAh lithium polymer battery with 5 days standby time

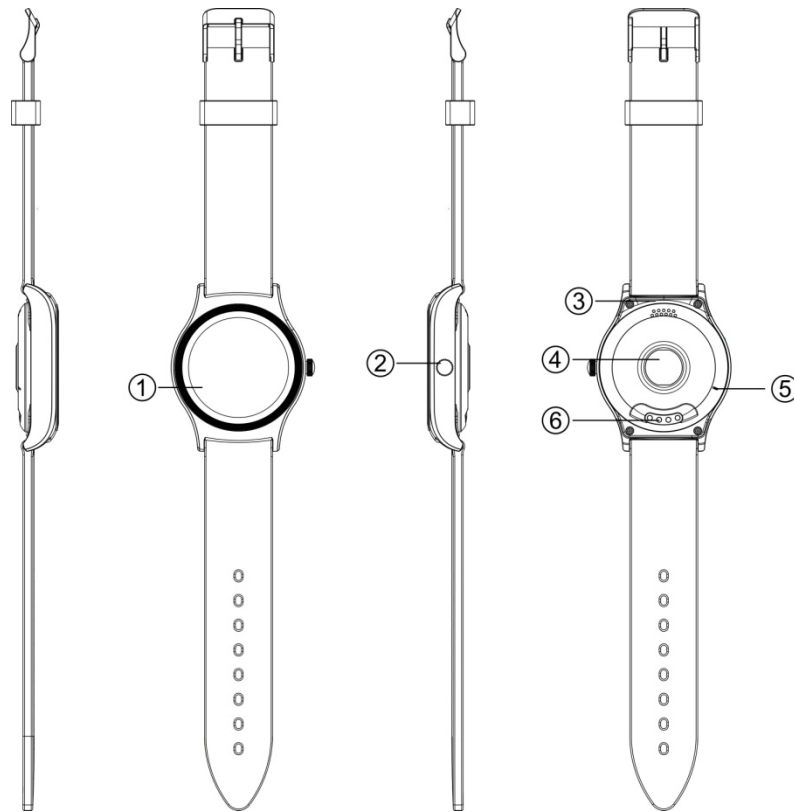

- Compatible with iOS7 or above and Android 4.4 and above

Overview

Smart Watch

1. Touch screen
2. Power button
3. Speaker
4. Heart rate sensor
5. MIC
6. POGO-Pin Charging terminals

Charging

- If you use a Power Adaptor (Not included), Power Adaptor current is: 5V, 500mA.

- It takes 2-hours to fully charge the smart watch, please follow steps below to charge.

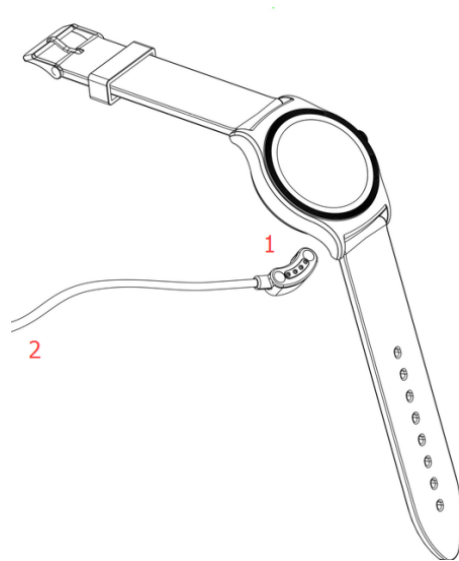

- 1. Make sure the POGO-pins on the Charging Cable fit correctly onto the charging terminals on the back of smart watch.
 2. Plug the big end of the USB cable to a power source

Charging when power off

Charging when power on

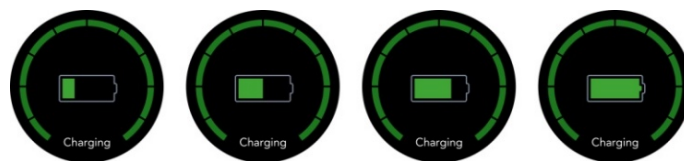

How to use

- **Turn on:** Hold press power button in 3 seconds
- **Go to main menu:** Swipe from right to left on watch face interface
- **Switch main menu:** Swipe up/ down
- **Confirm:** Tap the icon
- **Exit:** Swipe from left to right
- **Return to watch face interface:** Short press power button on any interfaces
- **Check notifications:** Swipe from left to right on watch face interface
- **Switch submenu/ shortcuts:** Swipe up/ down
- **Turn off:** Hold press power button in 3 seconds



When turning on smart watch, you will see the watch face.

Swipe left to get into sport mode, right to get into notification mode, up to get into settings and down to get into activity info screen.

If you connect more faces in settings you can slide to those aswell by swiping either up/down or left/right.

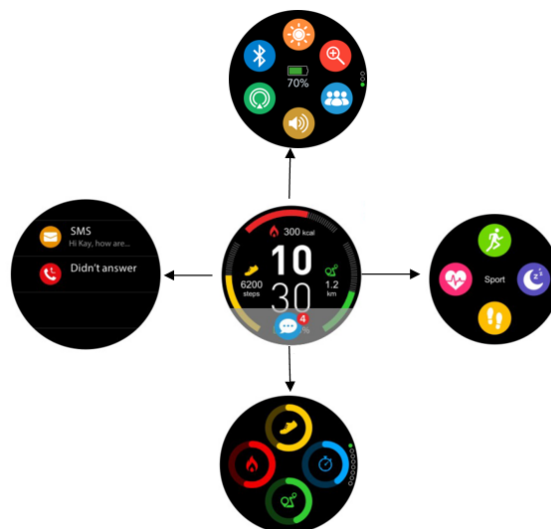

Pair with smart phone

Mobile phone requirement: Android 4.4 and above, iOS7.0 and above



Search for, and download app called: **DENVER SW-450** from Google Playstore or Apple Appstore.

1. Enable Bluetooth on your smart phone
2. Open DENVER SW-450 App on your smart phone, set up your profile on Settings.
3. Tap “Connect Smart Watch” on Settings, select the name of your smart watch (or your smart watch name_LE on iPhone) in the list of devices for connection.

Step 2: Pairing for calling function (Only for iPhone)

Go to iPhone “Settings” → “Bluetooth” and select your smart watch name in the list of devices for connection.

Bluetooth icon explanation

	Means Bluetooth 3.0 connected (for making and receiving calls with smart watch)
	Means Bluetooth 4.0 connected (for activity data and notifications synchronization)
	Means Bluetooth 3.0 & 4.0 connected

Sport mode

If you have turned on Heartrate function, when using the watch for sports, it will track your heartrate. After your activity you can see this information in the app.

1. You can tap below icon on main menu to enter sport mode.

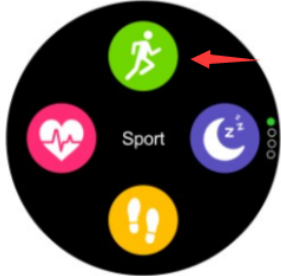

2. Multi-Sport mode: with 4 sport mode as below.

Slide up/ down to select the sport mode you want to start.



Pedometer

The watch has built-in pedometer, and will track your steps during the day. In the app you can set up your daily goal. You can also turn on sedentary alarm.

The watch also registers your sleep and will give you an overview over your sleep in the app (show you how many hours of deep sleep and light sleep you have)

Voice activation

You can use the watch with Siri/Google talk when connected to your smartphone. E.g. ask it to send an SMS, ask what the weather is like (this information will be shown on your phone, not on the watch).

Calls

You can both make a call and take a call on the watch itself. There are built-in speaker and microphone. (please notice you need the phone within Bluetooth range).

SMS/notifications

Will be shown on the watch when paired with your smartphone.

We hope you like your new smartwatch. If you want more information there is a full manual in English on our website.

ALL RIGHTS RESERVED, COPYRIGHT DENVER ELECTRONICS A/S

DENVER[®]
denver-electronics.com

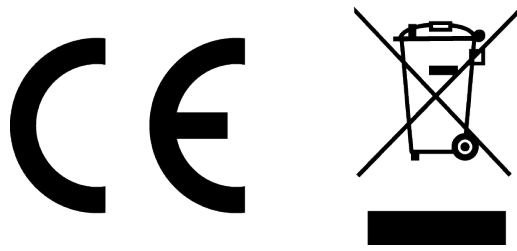

Electric and electronic equipment and included batteries contains materials, components and substances that can be hazardous to your health and the environment, if the waste material (discarded electric and electronic equipment and batteries) is not handled correctly.

Electric and electronic equipment and batteries is marked with the crossed out trash can symbol, seen below. This symbol signifies that electric and electronic equipment and batteries should not be disposed of with other household waste, but should be disposed of separately.

As the end user it is important that you submit your used batteries to the appropriate and designated facility. In this manner you make sure that the batteries are recycled in accordance with legislature and will not harm the environment.

All cities have established collection points, where electric and electronic equipment and batteries can either be submitted free of charge at recycling stations and other collection sites, or be collected from the households. Additional information is available at the technical department of your city.

Hereby, Inter Sales A/S declares that the radio equipment type SW-450 is in compliance with Directive 2014/53/EU. The full text of the EU declaration of conformity is available at the following internet address:

<http://www.denver-electronics.com/denver-sw-450/>

Operating Frequency Range: 256MHZ

Max Output Power: 0.56W

Imported by:

DENVER ELECTRONICS A/S

Omega 5A, Soeften

DK-8382 Hinnerup

Denmark

www.facebook.com/denverelectronics